

## Understanding EDID - Extended Display Identification Data

### Table of Contents

What is EDID?.....	2
Where is EDID Utilized? .....	2
History .....	2
What EDID Information is Exchanged Between Display and Source? .....	3
EDID/DDC Protocols .....	4
EDID Issues .....	5
EDID Tools .....	6
EDID Solutions .....	6

### Abstract

The EDID data structure is used extensively to communicate display capabilities to attached computer graphics cards and other source devices. This paper offers an in-depth look into the operational process and pitfalls users may encounter when integrating EDID reliant source and display devices.

white paper

## What is EDID?

EDID data exchange is a standardized means for a display to communicate its capabilities to a source device. The premise of this communications is for the display to relay its operational characteristics, such as its native resolution, to the attached source, and then allow the source to generate the necessary video characteristics to match the needs of the display. This maximizes the functional compatibility between devices without requiring a user to configure them manually, thus reducing the potential for incorrect settings and adjustments that could compromise the quality of the displayed images and overall reliability of the system.

## Where is EDID Utilized?

Generally, the source device will be a computer graphics card on a desktop or laptop PC, but provisions are in place for many other devices, including HDTV receivers and DVRs, DVD and Blu-ray Disc players, and even gaming consoles, to read EDID and output video accordingly. Originally developed for use between analog computer-video devices with VGA ports, EDID is also now implemented for DVI, HDMI, and DisplayPort.

## History

EDID was developed by VESA - the Video Electronics Standards Association, with version 1.0 introduced in 1994 within version 1.0 of the DDC standard. See Table 1.

Prior to the development of EDID, pins 4, 11, 12, and 15 on the VGA connector were sometimes used to define monitor capabilities. These ID bit pins carried either high or low values to define different screen resolutions. VESA extended this scheme by redefining VGA connector pins 9, 12, and 15 as a serial bus in the form of the DDC - Display Data Channel. This allowed for much more information to be exchanged, so that EDID and other forms of communication were possible between the source and the display.

The original DDC protocol defined 128 bytes to be sent from the display to the video source, with data formatting defined by the EDID specification.

As display types and capabilities increased, 128 bytes became insufficient, and both EDID and DDC were extended so that multiple 128-byte data blocks could be exchanged. This is known as E-EDID and has been implemented in many consumer devices. In fact, the CEA - Consumer Electronics Association has defined its own EDID extensions to cover additional video formats and to support advanced multi-channel audio capabilities.

EDID Development History	
<b>EDID</b>	Defines the data structures sent from a video display to a source over E-DDC lines to describe its capabilities
<b>EDID 1.0</b>	Defined original 128-byte data structure (Deprecated)
<b>EDID 1.1</b>	Defined some alternative uses for space in data structure (Deprecated)
<b>EDID 1.2</b>	Defined some alternative uses for space in data structure (Deprecated)
<b>EDID 1.3</b>	Current definitions for 128-byte EDID data fields
<b>EDID 2.0</b>	Introduced new 256-byte data structure
<b>E-EDID</b>	Defined optional additional 128-byte extension blocks for EDID 1.3, incorporated EDID 2.0 as optional extensions
<b>DisplayID</b>	Introduced variable length data structure

Table 1: EDID Development History

### VGA - VESA E-DDC host assignment

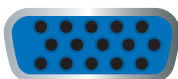

PIN #	SIGNAL NAME	PIN #	SIGNAL NAME
1	Red	9	DDC 5V supply
2	Green	10	Sync return
3	Blue	11	Monitor ID bit 0
4	Monitor ID bit	12	Bi-directional data (SDA)
5	Return (GND)	13	Horizontal sync
6	Red return	14	Vertical sync
7	Green return	15	Data clock (SCL)
8	Blue return		

VGA-VESA Pin Assignments

Address (Decimal)	Data	General Description
0-7	Header	Constant fixed pattern
8-9	Manufacturer ID	Display product identification
10-11	Product ID Code	
12-15	Serial Number	
16-17	Manufacture Date	
18	EDID Version #	EDID version information
19	EDID Revision #	
20	Video Input Type	Basic display parameters. Video input type (analog or digital), display size, power management, sync, color space, and timing capabilities and preferences are reported here.
21	Horizontal Size (cm)	
22	Vertical Size (cm)	
23	Display Gamma	
24	Supported Features	
25-34	Color Characteristics	Color space definition
35-36	Established Supported Timings	Timing information for all resolutions supported by the display are reported here
37	Manufacturer's Reserved Timing	
38-53	EDID Standard Timings Supported	
54-71	Detailed Timing Descriptor Block 1	
72-89	Detailed Timing Descriptor Block 2	
90-107	Detailed Timing Descriptor Block 3	
108-125	Detailed Timing Descriptor Block 4	Number of (optional) 128-byte extension blocks to follow
126	Extension Flag	
127	Checksum	

Table 2: EDID File Structure

In December 2007, VESA released DisplayID, a second generation of EDID. It is intended to replace all previous versions. DisplayID is a variable length data structure, of up to 256 bytes, that conveys display-related information to attached source devices. It is meant to encompass PC display devices, consumer televisions, and embedded displays such as LCD screens within laptops, without the need for multiple extension blocks. DisplayID is not directly backward compatible with previous EDID/E-EDID versions, but is not yet widely incorporated in A/V products.

## What EDID Information is Exchanged Between Display and Source?

The base EDID information of a display is conveyed within a 128-byte data structure that contains pertinent manufacturer and operation-related data. See Table 2. The current EDID version defines the structure as follows:

**Vendor/Product Identification Block** – The first 18 bytes identify the display manufacturer and product, including serial number and date of manufacture.

**EDID Structure Version & Revision** – The next two bytes identify the version and revision of the EDID data within the structure.

**Basic Display Parameters/Features** – The next five bytes define characteristics such as whether the display accepts analog or digital inputs, sync types, maximum horizontal and vertical size of the display, gamma transfer characteristics, power management capabilities, color space, and default video timing.

**Color Characteristics** – The next 10 bytes define the RGB color space conversion technique to be used by the display.

**Established Timings** – The next three bytes define the VESA-established video resolutions/timings that are supported by the display. Each bit represents an established timing such as 640x480/60. The last of the three bytes defines the manufacturer's reserved timing, if any.

**Standard Timing Identification** – The next 16 bytes define eight additional video resolutions supported by the display. These resolutions must adhere to standard VESA defined timings.

**Detailed Timing Descriptions** – The next 72 bytes are organized into four 18-byte blocks that describe additional video resolutions in detail, so that custom video timings/resolutions can be supported. The first of the four blocks is intended to describe the display's preferred video timing. The timing data can be structured according to the VESA GTF - Generalized Timing Formula or CVT - Coordinated Video Timings standards.

Address (Decimal)	General Description
0	Always "2"
1	Revision number
2	Pointer to detailed timing descriptors "d"
3	Number of detailed timing descriptors "n"
4 to d-1	CEA data block collection describing various capabilities including colorimetry, audio data rates, number of audio channels, and speaker configuration
d to d+17	First 18-byte detailed timing descriptor
	• • •
d+18(n-1) to d+18n-1	Final 18-byte detailed timing descriptor
d+18n to 126	"0" padding
127	Checksum

**Table 3:** CEA-861-E EDID Extension

**Extension Flag** – EDID versions 1.3 and higher allow for additional 128-byte blocks of data to describe increased capabilities. This byte indicates the number of additional extension blocks available. Various structures for these extension blocks have been defined, including DI-EXT - Display Information Extension, VTB-EXT - Video Timing Block Extension, and LS-EXT - Localized String Extension.

**CEA-861 Extension** – The most prevalent EDID extension is CEA-861, defined to support advanced capabilities of consumer devices incorporating HDMI. The general structure of CEA-861 extension data is shown in Table 3. CEA-861 allows for a variable number of 18-byte detailed timing descriptions to be included. For example, video timing details for 1080i, which is popular for consumer displays but not for PCs, can be communicated. CEA-861 also specifies a variable length "CEA Data Block Collection" for describing parameters such as display colorimetry, and advanced audio capabilities including surround sound format, audio sampling rate, and even speaker configuration and placement. The significance of the CEA-861 extension is that it aims to address previous operational disparities experienced with integrating consumer-based display devices into computer-based commercial A/V systems, allowing for proper conveyance of EDID information between devices.

## EDID/DDC Protocols

The DDC uses a standard serial signaling scheme known as the I<sup>2</sup>C bus. I<sup>2</sup>C is used extensively where electronic devices and components need to exchange information, due to its simplicity, low pin count, and bi-directional capability. An I<sup>2</sup>C bus consists of three wires: SDA - data, SCL - clock, and a logic "high" DC pull-up voltage. For the DDC, the logic "high" voltage is specified to be +5V.

EDID information is typically exchanged when the video source starts up. The DDC specifications define a +5V supply connection for the source to provide power to a display's EDID circuitry so that communication can be enabled, even if the display is powered off. At startup, the video source will send a request for EDID over the DDC. The EDID/DDC specifications support hot plug detection, so that EDID information can also be exchanged whenever a display is re-connected to a video source. Hot plug detection is not supported for VGA, but is supported in digital interfaces including DVI, HDMI, and DisplayPort. For these interfaces, the display device will supply a voltage on an HPD - Hot Plug Detect pin, to signal to the video source device that it is connected. The absence of a voltage on the HPD pin indicates disconnection. The video source device monitors the voltage on the HPD pin and initiates EDID requests as it senses incoming voltage.

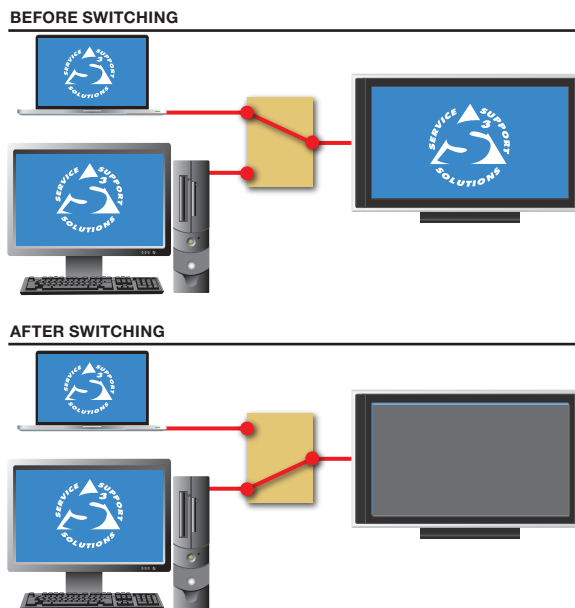

**Figure 1:** EDID problems can result in the loss of an image when a new source is selected.



**Figure 2:** The source resolution does not match that of the display, resulting in a fuzzy, distorted image.

## EDID Issues

Display devices can have various levels of EDID implementation and, in some cases, they may lack EDID information altogether. Such inconsistencies can cause operational issues ranging from overscan and resolution problems, to the display device not displaying the source content at all.

The following are examples of some potential issues with EDID communications, along with the possible causes:

### Problem

**No image is shown on the display.**

#### Possible Cause

- The source device, such as a PC graphics card, or laptop, cannot read the EDID information from the display. As a result, in some cases the PC will not output any video signal.

### Problem

**The display loses the image when a new source has been selected.**

#### Possible Cause

- This is a common occurrence with VGA sources, due to the lack of hot plug detection.
- While hot plug detection is supported for DVI, HDMI, and DisplayPort, EDID communication problems can arise from inconsistencies in the implementation of HPD signaling between devices from different manufacturers. This frequently becomes an issue for professional integration, since the ability to switch digital video signals is a necessity.

### Problem

**An image is shown, but the source resolution does not match that of the display.**

#### Possible Cause

- A PC cannot read the EDID information, so it defaults to a standard resolution, such as 640x480. If the user subsequently attempts to manually set the resolution to match the display, some graphics card drivers may enforce the lower default resolution and create a scrolling/panning desktop without actually changing the video resolution.
- The PC is able to read the EDID information, but the graphics card limits the output resolution to XGA 1024x768, a resolution most displays can accommodate, ensuring a usable image and reducing the likelihood of no image being displayed. If this does not match the native resolution of the display, fonts will likely appear to be abnormally large, small, or fuzzy.
- The PC is connected to multiple displays with different native resolutions. Since it can only read EDID from one display, the output will be mismatched in resolution with all other displays, resulting in less than optimal image quality, or no image displayed at all. This issue is a common occurrence in professional systems when video signals need to be distributed or routed to multiple displays.

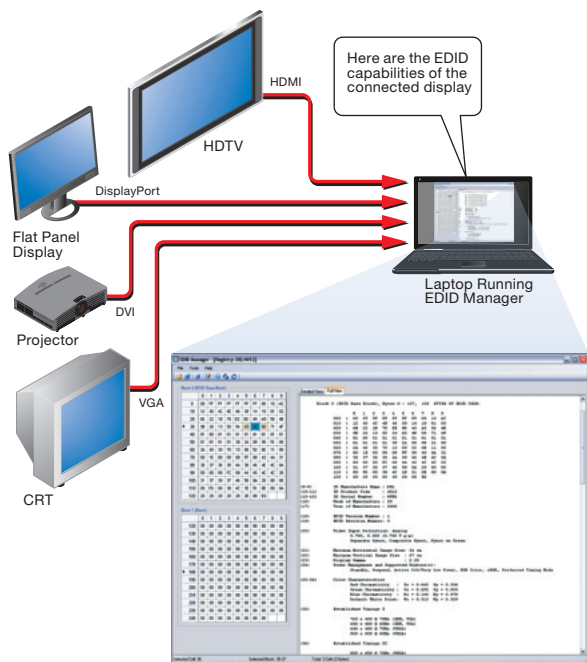

**Figure 3:** EDID Manager software reports the EDID information of displays connected via VGA, DVI, HDMI, or DisplayPort.

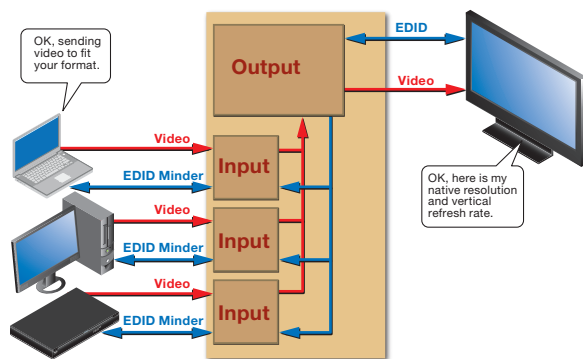

**Figure 4:** EDID Minder Communications



**Extron EDID 101D and EDID 101V EDID Emulators with EDID Minder**

## EDID Tools

Software such as Extron EDID Manager can be used to help troubleshoot possible compatibility issues between the display device and the source. EDID Manager is available as a free download from Extron's Web site, [www.extron.com](http://www.extron.com). It is a useful software tool that allows you to read the display's EDID and determine whether a graphic card and the display device may be experiencing EDID handshake problems.

## EDID Solutions

A/V systems typically comprise several remotely located displays and often include multiple source devices. It is important to realize this can potentially contribute to EDID-related issues. The necessity to switch, distribute, and route signals from sources to displays presents a considerable challenge in terms of ensuring proper EDID communications and therefore reliable system operation.

For example, systems that employ RGBHV-based distribution have no means of passing EDID information from the display to the source. This could become problematic in system designs where laptops and computers with expectation of seeing EDID are connected into the system. Since EDID information is not being provided to these devices, some of the aforementioned EDID communication issues may occur.

Extron products include features to help prevent or solve many of them by properly managing EDID communications between sources and displays in A/V systems. These features provide automatic and continuous EDID management with attached source devices, ensuring proper power-up and reliable output of content.

**EDID Emulation** is a feature of many Extron DVI and HDMI products, including switchers, distribution amplifiers, and matrix switchers. It maintains constant EDID communication with source devices by providing pre-stored EDID information for various signal resolutions. A user can select the desired signal resolution, and then the corresponding EDID block is conveyed to all attached source devices. This EDID information is constantly available to the sources, even in a switching application where inputs are regularly selected and de-selected. The output of the sources should match the native resolution of the intended display device.

**EDID Minder™** is an advanced, Extron-exclusive technology for EDID management. It encompasses EDID Emulation, but also incorporates an additional level of "intelligence." Extron products with EDID Minder can communicate with the display device, and automatically capture and store EDID information from the display. See Figure 4. This captured information can then be used as the reference EDID for the sources.



**Extron DXP 88 DVI Pro 8x8 DVI Matrix Switcher  
with EDID Minder**

EDID Minder is a standard feature in most Extron DVI and HDMI extenders, switchers, distribution amplifiers, and matrix switchers, as well as products that incorporate DVI or HDMI switching.

EDID Minder implementation. Matrix switching environments represent the most difficult EDID management situation, with simultaneous EDID communications required for multiple inputs and outputs. The displays connected to the outputs are very likely to be of different models and native resolutions. The EDID information between them is different and needs to be conveyed to the source devices. Proper EDID management within the system is crucial to consistent and reliable operation.

Extron HDMI and DVI matrix switchers with EDID Minder achieve this by managing EDID communications for each input/output tie. EDID Minder first analyzes the EDID for all displays connected to the system, applies a complex algorithm to determine a common resolution, refresh rate and color space, and then uses the EDID protocol to set up the input sources. This powerful convenience feature simplifies system setup for the integrator, helps ensure consistent and reliable image display, and makes system operation virtually transparent to the end user.

Extron Electronics, headquartered in Anaheim, CA, is a leading manufacturer of professional A/V system integration products. Extron products are used to integrate video and audio into presentation systems in a wide variety of locations, including classrooms and auditoriums in schools and colleges, corporate board rooms, houses of worship, command-and-control centers, sports stadiums, airports, broadcast studios, restaurants, malls, and museums.

For additional information, please call an Extron Customer Support Representative at: 800.633.9876 (inside USA and Canada only) or 714.491.1500 for Extron USA; +800.3987.6673 (inside Europe only) or +31.33.453.4040 for Extron Europe; +800.7339.8766 or +65.6383.4400 for Extron Asia; +81.3.3511.7655 for Extron Japan.

www.extron.com  
© 2009 All rights reserved.